

O FORM MOUNTINGS

Description:

Vibracoustics Ltd O Form Mountings (because of their relatively soft spring rates also known as low frequency mounts) consist of a rubber ring bonded to two plates with fastening screws. This method of construction is particularly suitable for vibration isolation as often occurs when light equipment is softly mounted or suspended.

The standard off-the-shelf part is made of highly elastic natural rubber. Some applications require increased damping characteristics. Existing tools can produce O form mountings with increased damping by proper selection of specially formulated rubber mixtures.

Vibracoustics Ltd O Form Mountings are designed to have different spring rates for the three different coordinates (refer to the corresponding diagram). These mounts are “soft” in X-direction, somewhat “harder” in Y-direction and “hardest” in Z-direction, considering that these are fairly soft mounts overall.

Typical Applications Include:

- Impact-free isolation of instruments.
- Electric or electronic systems.
- Mounting of light machinery.
- Mounting of light precision apparatus.

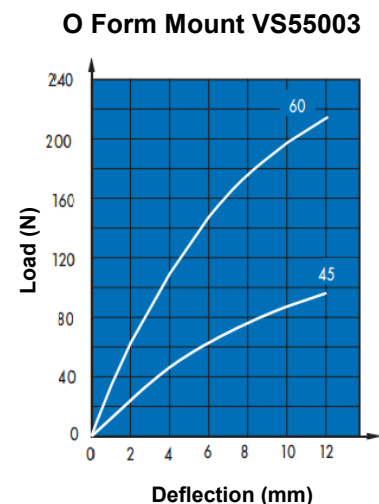
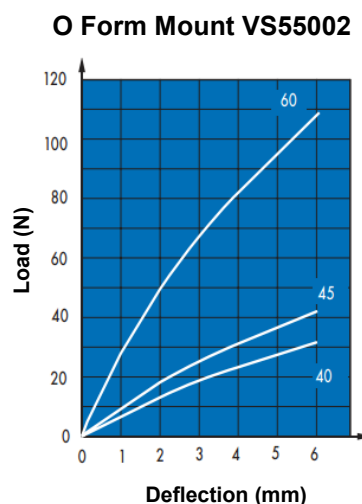
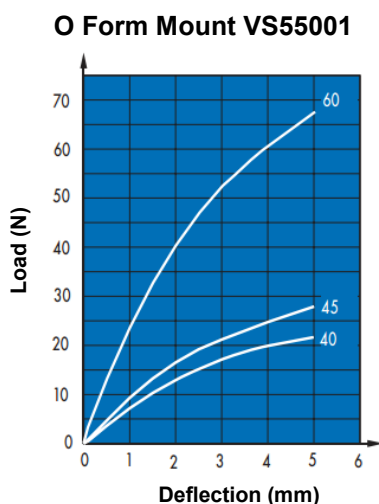
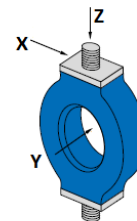
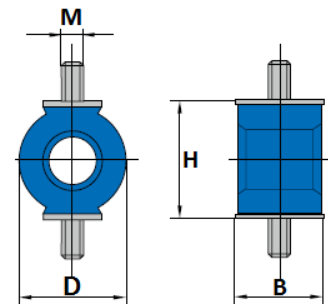

Part No.	Shore Hardness	Dimensions (mm)				Load Direction Z	
		D	H	B	M	Max Load (N)	Max Defl. (mm)
VS55001	N60	14	18	15	M4 x 7	60	4
VS55002	N60	25	30	22	M5 x 10	110	6
VS55003	N60	36	38	28	M6 x 9.5	215	12

Table values are for N60 shore mounts, for N40 & N45 refer to Vibracoustics Ltd.



Vibracoustics is continually seeking to improve products and reserves the right to change designs and specifications without prior notice or alteration of literature.

For applications and technical assistance please contact [Vibracoustics](http://www.vibracoustics.com), see index Ref 00-A-01

