

SPRING HANGERS

Description:

Vibracoustics Ltd Spring Hangers are simple to assemble and install on site.

Standard units give up to 25mm deflection (Where greater deflections are required non-standard springs may be fitted).

Typical Applications Include:

- Pipework supports.
- Ceiling hangers.
- Equipment hangers.

Housing Finishes: STANDARD: Stove enamel
OFFSHORE: Flame spray Zinc to BS 2569

Spring Finishes: STANDARD: Heavy grease
OFFSHORE: Plated & Painted (Or to clients specification)

Ancillaries: Plated
Elastomer: Neoprene

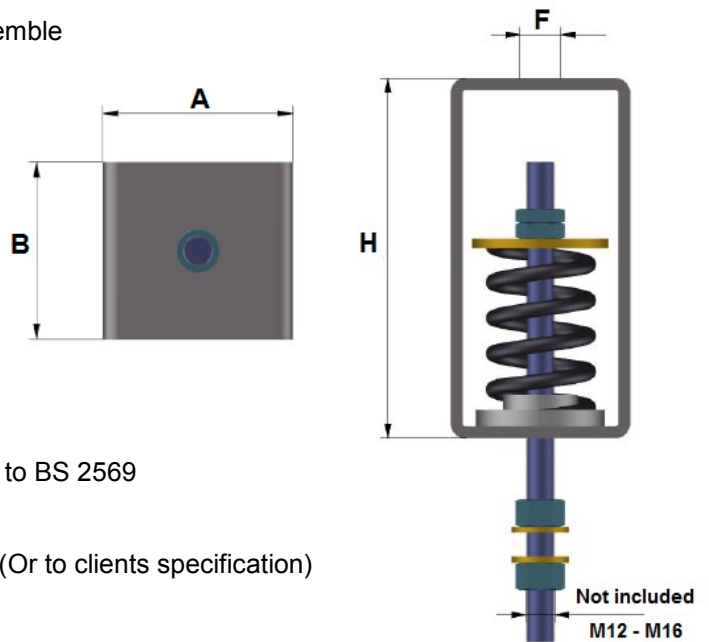

Standard supply includes the housing, spring, spring end caps and elastomer seating. Drop-rods and top fittings can be supplied as extras to the clients requirements.

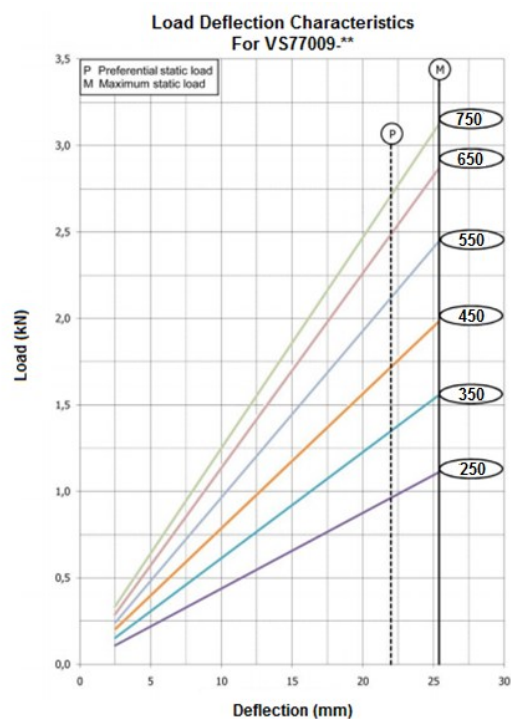
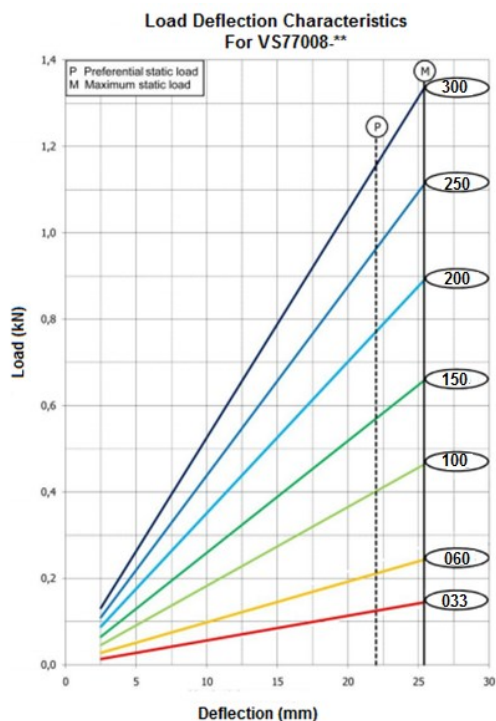

| Part No. | Dimensions (mm) | | | | |
|----------|-----------------|----|----|-----|-----------|
| | A | B | F | H | M |
| VS77008 | 60 | 50 | 14 | 120 | M10 / M12 |
| VS77009 | 75 | 70 | 17 | 150 | M12 / M16 |